

# CONVECTAIR

## Legato Split-Type Room Heat Pump

The Legato Heat Pump by Convectair delivers efficient heating and cooling with whisper-quiet operation. Its smart controls and versatile design make it ideal for both residential and commercial spaces requiring precise temperature management.

### Performance up to

**-29°C  
-20°F**

Cooling

**-30°C  
-22°F**

Heating

### Up to

**26 SEER2  
IN COOLING**

**15 HSPF2  
IN HEATING**



Indoor Unit

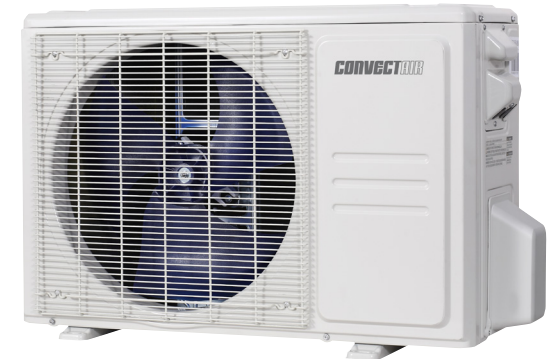

Outdoor Unit

### FINISH

- Premium white plastic housing with sleek, modern design
- Standard; white

### VOLTAGE

- 230/208V 60 hz, 1-phase

### CONSTRUCTION

- Uses R454B refrigerant for superior efficiency and reduced environmental impact
- Built-in refrigerant leak detection system
- Indoor unit features multi-speed cross flow fan system
- Outdoor unit equipped with Hyper Heat Inverter compressor
- PTC heating pan for superior cold climate performance
- Single zone configuration for targeted comfort
- Enhanced cold weather operation with specialized oil warming system
- Easy-access washable filters for simplified maintenance
- Auto-clean functionality prevents mold growth
- Golden fin coating technology providing 70% better corrosion resistance

### COMPRESSOR

- High-performance inverter compressor operates efficiently in extreme temperatures, delivering reliable heating and cooling in any climate.

### CONTROL

- Includes intuitive remote control and WIFI-enabled Convectair Connect app. 
- Temperature range: 16-30°C/61-86°F for both heating and cooling
- Five-speed fan control: Turbo/High/Medium/Low/Silent
- Ultra-quiet 20dB operation in Silent mode
- Multiple operating modes: Cooling, Heating, Dehumidification, Fan, and Auto
- Optional 120V wired wall thermostat for alternate control
- Optional 24V interface adapter for low voltage thermostat compatibility
- Smart Inverter Detector available for system diagnostics

### WARRANTY

- 10-year warranty on parts and compressor (no labour)

### APPLICATIONS

- Residential: Single-family homes, apartments, condominiums, and home additions
- Commercial: Professional offices, hospitality spaces, and dining establishments
- Specialty Spaces: Temperature-controlled workshops and garages
- Challenging Environments: Climate-controlled sunrooms and attic conversions

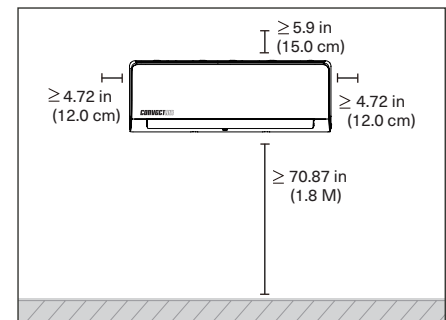

Side		Above		Below	
in	cm	in	cm	in	meter
4.72	15.0	5.9	15.0	70.87	1.8

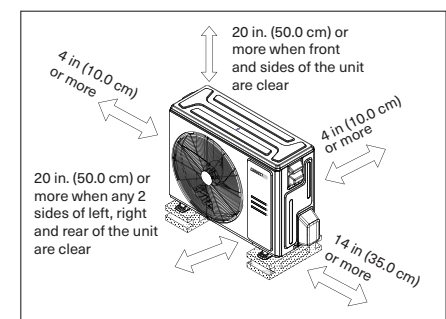

Minimum clearances							
Front		left Side		right side		Above	
in	cm	in	cm	in	cm	in	cm
20	50.0	4	10.0	14	35.0	20	50.0

**INVERTER**  **R454B**

It is recommended that all units be installed by a licensed electrical contractor in accordance with national and local codes. Consult [convectair.ca](http://convectair.ca) to find installation instructions for our heaters.



**10** year warranty on parts and compressor (no labour)

## Legato Split-Type Room Heat Pump

### Legato Split-Type Room Heat Pump Series

Product No.	Color	Description	Height		Width		Depth		Net Weight		SEER2	HSPF2
			in	cm	in	cm	in	cm	lb	kg		
500004479	White	9K BTU Indoor Unit Heat Pump	11.50	29.2	31.75	80.6	7.75	19.7	20.3	9.2	26.0	15.0
500004490	White	9K BTU Outdoor Unit Heat Pump	20.87	53.0	34.25	87.0	12.60	32.0	71.6	32.5		
500004491	White	12K BTU Indoor Unit Heat Pump	11.50	25.3	31.75	69.9	7.75	17.1	20.7	9.4	24.0	13.2
500004492	White	12K BTU Outdoor Unit Heat Pump	20.87	53.0	34.25	87.0	12.20	31.0	71.5	32.5		
500004493	White	18K BTU Indoor Unit Heat Pump	13.00	33.0	41.34	105.0	9.06	23.0	32.0	14.6	21.7	13.0
500004494	White	18K BTU Outdoor Unit Heat Pump	26.00	66.0	38.75	98.4	13.50	34.3	97.9	44.5		
500004495	White	24K BTU Indoor Unit Heat Pump	13.25	33.7	42.50	108.0	9.25	23.5	32.5	14.76	22.3	12.5
500004496	White	24K BTU Outdoor Unit Heat Pump	31.89	81.0	41.34	105.0	16.54	42.0	130.3	59.1		

#### Optional Accessories:

Material	EAN/UPC	Material description
500004911	781052157002	120V Wall Thermostat
500004912	781052157019	24V Interface
500004913	781052157033	Smart Inverter Detector for in field troubleshooting (Test Board)

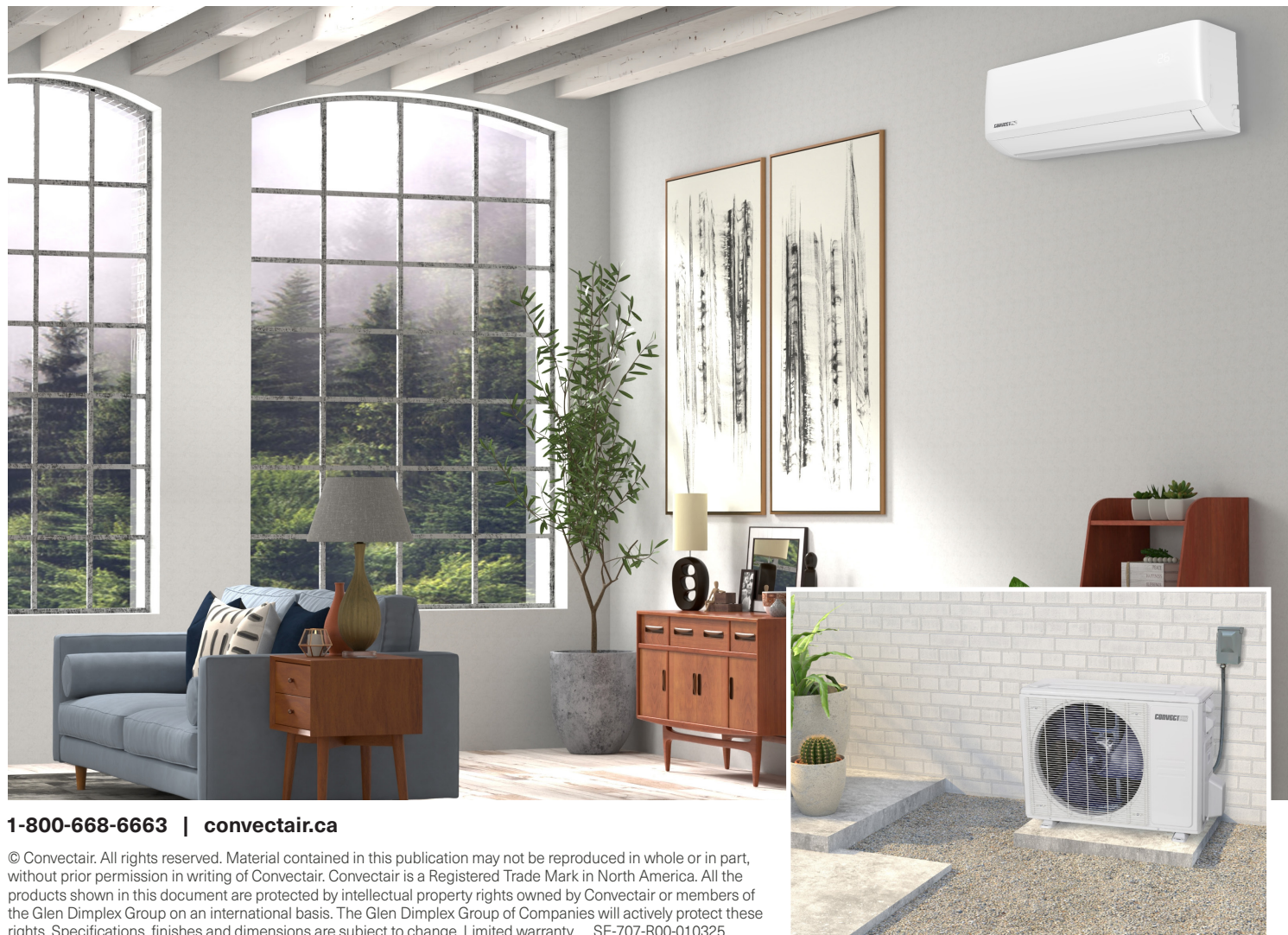

1-800-668-6663 | [convector.ca](http://convector.ca)

© Convector. All rights reserved. Material contained in this publication may not be reproduced in whole or in part, without prior permission in writing of Convector. Convector is a Registered Trade Mark in North America. All the products shown in this document are protected by intellectual property rights owned by Convector or members of the Glen Dimplex Group on an international basis. The Glen Dimplex Group of Companies will actively protect these rights. Specifications, finishes and dimensions are subject to change. Limited warranty. SE-707-R00-010325